

GoodNEWS

Lindfield URC's Village Magazine

November 2010

What is the Church?



- Update on our Students
- Read about the work of Release International
- Read our Minister's letter



FREE
PLEASE HELP YOURSELF

You, O Lord, have declared:
“My thoughts are not your thoughts,
Neither are your ways My ways.
As the heavens are higher than the earth,
So are My ways higher than your ways,
And My thoughts than your thoughts.”

Isaiah 55: 8-9

GoodNEWS November 2010

Produced for Lindfield United Reformed Church,
50 High Street, Lindfield, West Sussex, RH16 2HL
© Lindfield URC 2010

Editorial Team: Val Cookney (Editor), Jacqui Adams, Martin Hall, Carol and Stuart Marsh.

Editorial Oversight/Proof-reading: Carol and Stuart Marsh.

Setting: Tim Sanderson and Lydia Goodchild

Printing: Tom Burford.

Next Copy Date: 10th November 2010.

All contributions should be emailed to goodnews@lindfieldurc.org, or hard copy placed in the "GoodNEWS" pigeon hole at the rear of the church. Please ensure that you include your contact details in case of query. You can contact Val Cookney on 01444 440029.

DIRECTORY



Pastor: Rev. Charles Martin
Tel: 01444 482098 Mob: 07821 904785

Youth Pastor: Josh Thomas
Mob: 07598 779553

Church Secretaries:

Mrs Sue Waller
58, Queens Road, Haywards Heath, RH16 1EE
Tel: 01444 455047
Email: susanwaller@lineone.net

Mr David Jones
13, William Allen Lane, Lindfield, RH16 2SA
Tel: 01444 483037
Email: dlandfc13wal@talktalk.net

Church Treasurer and Accountant:

Michael J Davies
13, Savill Road, Lindfield, RH16 2NY
Tel: 01444 482024
Email: michael.j.davies21@btinternet.com

A list of serving Elders can be found in Who's Who?

Editorial



This issue begins with an article by Tim Sanderson, on 'What is the Church?' He highlights that the Church is not about physical buildings but a living, dynamic, changing group of people, who know Jesus as their Saviour or who are wanting to know more about who Jesus is.

We have an updated bookmark with our students' names; and Jonathan Hall writes in more detail about what he is up to now.

We have the usual information on events and concerts coming up in the next few weeks

Val

Cover photography by Chris Sanderson.

Chrissandy@aol.com.
[@shutterartchris](https://twitter.com/shutterartchris) (twitter).
www.flickr.com/photos/chrissanderson.

Dear Friends,



Time rushes on and memories of our weekend-away-at-home in September are beginning to fade. All the same, so many people were blest by the ministry of Ian Macfarlane, that the Elders have decided to invite him to visit us again at the end of November. We experienced a new freedom and touch of the Holy Spirit at Walstead and we want to make sure that we do not lose the spiritual momentum.

It was in the early 1970s that the Church began to re-discover the presence and gifts of the Holy Spirit. I was ordained in 1972, so this re-discovery has been the background to my ministry ever since. For some churches and individuals this has been a tremendous blessing. It has released opportunities and gifts that had either been forgotten, or never discerned in the first place. Sadly, for others it has been a threat and even a kind of condemnation. Now that God seems to be opening our fellowship to a deeper appreciation of the work and gifting of the Holy Spirit, we must ensure that no one feels threatened or misunderstands what's happening. Here are four things to keep in mind as we move forward together into the fullness of all God has for us.

- The Holy Spirit is not a separate part of God. He is the life of the risen Lord Jesus, active and present with His people. In St. John 14:18, speaking of the coming of the Holy Spirit, Jesus says "I will not leave you as orphans, I will come to you."
- No one should ever feel a "second-class Christian" if they don't feel excited and effervescent all the time. We couldn't have placed our faith in the Saviour in the first place had He not breathed life into us through the Holy Spirit. Ephesians 2:4&5 "God Who is rich in mercy, made us alive with Christ, even when we were dead in transgressions." That enlivening miracle is the work of the Holy Spirit.
- Experience is great, but faith is essential. It's wonderful to feel excited and full of spiritual blessing and we should welcome the touch of the Spirit and be grateful for it. The Christian life was not

meant to be a dreary trudge through the desert! All the same, true discipleship involves self-discipline and effort. We have a race to run and a prize to win and we can only do that as we look to Jesus and let Him energize us by His Spirit – Hebrews 12:1&2 “..... let us run with perseverance the race marked out for us. Let us fix our eyes on Jesus

- The gifts of the Holy Spirit – wisdom, knowledge, faith, healing etc: are not for individual use. They are, as 1 Corinthians 12:7 says “..... for the common good.” This new touch of blessing that God is giving us is for the whole church. No one need be left behind.

Our loving Lord has so much to give us. Let’s claim His gifts together and use them to live and witness more effectively for Him.

Your Pastor and friend,

Charles S. Martin

Prayer Focus

By the time you read this it will be a few weeks since *2010* ^{trial}. Is this now a nice



memory or are you seeking God’s potential for your Life and that of the Church?

This is first and foremost a work of the Holy Spirit but he uses various means. One is the Word and it is important that we make every effort to understand what God through the Spirit is saying to us.

Another is prayer and we would urge all to continue to seek the Lord that as individuals and as a Church we realise all that He has for us. This will involve waiting on Him and seeking his face in prayer. As well as our own prayer times, this could be something that we seek in the regular prayer meetings or for some in prayer triplets etc.

He has promised “the riches of his glorious inheritance in the saints, and his incomparably great power for us who believe. That power is like the working of his mighty strength which he exerted in Christ when he raised him from the dead, and seated him at his right hand in the heavenly realms”. God’s power is limitless and it is He who promises us the power to reach that potential. Jesus said “How much more will your Father in Heaven give the Holy Spirit to those who ask him”.

What is the Church?



I hope that for most of our readers the idea that “church” is not a building, but the people who meet there, is not novel. However, I want to open out this

idea, and show what the Bible says about the Church, and to touch on who the Church is, and how the Church should live in this day and age.

Nonetheless, in a short article, I can barely scratch the surface of such a vast subject; if you wish to discuss the topic further, please speak to me, or to Charles Martin (or your own minister, if not part of Lindfield URC).

In order to clarify, I will use the terms “Church” (capital ‘C’) when referring to the people, and “church” for the building where we happen to meet.

The word for Church in the New Testament is the Greek Ekklesia, which means “called out ones”. In fact, God’s people have been called by Him from at least the time of Abraham, who was called by God to leave his home town, and set out for a land “which he did not know” – Genesis 12:1-5. This calling then extended to the whole nation of Israel, who were instructed to bring blessing into the world that they came in contact with. The Christian Church continues this calling. Abraham’s calling was not on the basis of his merit; nor are we called because we have anything to offer to God, but that we may serve His purposes on the earth.

The Christian Church stems from Jesus’ calling first the twelve, then the wider group of disciples. Jesus stated “I will build my church...” (Matthew 16:18). The apostle Paul was clear that all those who believe in Jesus were called-out before the foundation of the world (Eph 1:4). Peter too, in his first letter chapter 2, speaks of us being chosen (1 Peter 2:9). Indeed, we who believe in Christ are part of God’s choosing of Jesus (v4). It is on the rock of belief in Jesus, and Jesus himself, that His Church has been, is being, and will be built (not upon Peter, or any other apostle). So, we also ‘like living stones, are being built into a temple of the Spirit to be a holy priesthood, offering spiritual sacrifices acceptable to God through Jesus Christ’ (v5). Having introduced a doxology of praise to Jesus, Peter returns, in verse 9, to his detailing the Church’s purpose: “But you are a chosen people, a royal priesthood, a holy nation, God’s special possession, *that* you may declare the praises of him who called you out of darkness into his wonderful light” (my emphasis).

So, our first analogy for the Church is a spiritual 'building', not of bricks, stones and mortar, but the living, breathing people of God, who are building our own lives on the rock of obedience to Jesus (Matthew 7:24-27).

Charles Martin spoke recently of the church being either an Ark – for the safety only of the members, or a Lifeboat – taking to the seas to rescue those in danger. He was clear that Jesus would choose the latter as the correct picture. The function of a priest is to represent man before God and God before man; so in Peter's description above, we are called out to present God's kingdom of light to a people in darkness.

Paul also speaks of the Church as Christ's building that He now inhabits and that He causes to grow. "Now, therefore, you are no longer strangers and foreigners, but fellow citizens with the saints and members of the household of God, having been built on the foundation of the apostles and prophets, Jesus Christ Himself being the chief cornerstone, in whom the whole building, being fitted together, grows into a holy temple in the Lord, in whom you also are being built together for a dwelling place of God in the Spirit" (Ephesians 2:19-22). However, another favourite picture of the Church is Jesus' body. In 1 Corinthians 12:12 – 31, he describes how the parts of the body exist for one another. So in the Church, as Christ's body, we live to encourage, build up, heal and correct one another – with the purpose that we are strong and healthy in order to fulfil our purpose as the spiritual building (or lifeboat). The following chapter underlines the way in which this is to be continued – in love for one another, as Charles confirmed in his message referred to above.

Both Peter and Paul speak of another key to entering Christ's Church – what are His building materials? These include spiritual values such as love, hope, faith, joy, peace, patience, wisdom and humility, to name a few. Only the Master Builder, Christ Jesus, can build His Church with these spiritual materials.

The activity of the Church is therefore to be "24/7" to use a modern idiom. We maintain our relationships with one another, and present Jesus to the world, day in day out, and not merely at our meeting on one day of the week.

Jesus modelled this building of His Church by relationship and teaching. His great commission at the end of Matthew (28:16 – 20) includes both the outward (...disciples of **all nations**...) and inward aspects mentioned above (make disciples.....teaching them to obey everything I have commanded you).

What of the buildings?

Church, in the Bible, is not described as a cathedral or any sort of building. The first-century Church brethren met in members' private residences (Romans 16:5; 1 Corinthians 16:19), as they sometimes do today. The apostle Paul sometimes spoke to brethren, as well as potential converts and perhaps curious listeners, in various Jewish synagogues. Nevertheless, as the Church grew in size, was increasingly expelled from the Jewish tradition, and extended to Gentile areas where no other synagogue existed; it became expedient to construct buildings for the express purpose of meeting together. There is no inherent merit in meeting in either a grand building, a humble house, or a community hall - the purpose being to fulfil the commission given to the Church.

Church traditions

Over the years churches have built up many traditions, most of which are helpful in pointing members, and others, to biblical truths. However, I believe that there are only two traditions that are foundational to Church life. Both were instituted by Jesus, by example and command:

Baptism following repentance and faith

Jesus himself set the example of being baptised by John (Matthew 3:13 - 17; Mark 1:9 - 11; Luke 3:21 - 22). John's baptism was a "baptism of repentance" (Matthew 3:11) yet despite John's protestations that he should be baptised by Jesus (who had no need to repent) Jesus submitted to this act, as fitting to fulfil his Father's will (3:14 - 15). Once again, in his commission at the end of Matthew, Jesus commanded his followers to baptise those who they make disciples of.

Holy Communion/Lord's Supper

Similarly, the night before his crucifixion, Jesus partook of the Jewish Passover meal, and applied this to himself, as the true Lamb of God through whom we obtain redemption from the power and penalty of sin. He then commanded that we continue to remember Him, by eating and drinking in the same fashion.

We may therefore identify the members of the Church, by our mutual participation in these two sacraments.

As Lindfield United Reformed Church (and the other Church fellowships in

Lindfield) we meet together regularly to enter into the purposes described above. As such the local church will include a mix of those people who are part of the Church – having recognised God’s calling, and responded in repentance, faith and obedience through Jesus Christ, being ‘born again’; with others who are enquiring, but have not yet understood and responded. We may also find those who are opposed to the Christian message amongst us – Jesus made it clear that the kingdom of heaven would grow up alongside “weeds” (Matthew 13:24 – 30, 36 – 43), and that not all within the church community would be genuine (Matthew 7:15 – 23). Nonetheless, He instructs us not to uproot the (apparent) impostors, but to allow God to distinguish at the right time (13:28b – 30).

May we be encouraged as we reflect upon our holy calling in Jesus, challenged by the tasks and opportunities to serve the one we love, and sure that we are building on the right foundations.

Tim Sanderson

The Fellowship

The meeting this month is on Wednesday 24th at 2.30 p.m. Our Speaker is Kay McIntosh and the title of her talk is, ‘As Time Goes By’

We look forward to welcoming her and all our regular friends, and also any new people who would like to join us.

There will be the usual Bring and Buy Stall.

There is an addition to our programme. As there is no meeting in December, our date being so near to Christmas, we are having a Coffee Morning on Saturday 8th January 2011 at 10.30 a.m. This is with our friends of the Art Group, who will display some of their talented work. Our usual January meeting is on Wednesday 26th.

Winifred Scopes

ALPHA update

The first three *ALPHA* meetings were well attended with 18 to 20 people each evening. Much stimulating discussion has resulted from the DVD presentations. Please continue to pray for our guests that they will meet with Jesus in a new and living way. Also for the Leaders and Helpers, that we will be wise and loving in presenting Jesus to our Guests.

The Away Day takes place on Saturday 6th November, when we will introduce the work of the Holy Spirit.

Monthly Mission Giving – November

This month we devote our giving to the work of RELEASE INTERNATIONAL supporting the persecuted church worldwide.

Release International was inspired and founded through the first-hand experience of persecution by Pastor Richard Wurmbrand, who was imprisoned for fourteen years and tortured by the Romanian secret police during the Cold War years of the 1950s and 1960s. He spent three years in solitary confinement in a cell thirty feet below ground, never seeing sun, moon, or stars, flowers or snow, never seeing another man except for the guards and interrogators who beat and tortured him.



Release International was founded in 1968, when it was known as Christian Mission to the Communist World. Richard Wurmbrand himself died in February 2001, but his vision and passion to serve persecuted Christians around the world continues in the ministry of Release International today.

Release International serves the persecuted church around the world in five key ways:

1. Providing for the needs of the families of martyrs and prisoners. Financial and medical help is provided, assistance for families to become self-sufficient in the longer term and orphans cared for.
2. Helping evangelical churches to survive persecution and its effects, assisting leaders and believers to pay fines imposed on them by the police, providing "safe houses" for new believers in dangerous circumstances.
3. Helping the persecuted church win to Christ those who are opposed to the gospel. Release International helps to strengthen the persecuted



church in its mission by supporting the work of local pastors and evangelists, who often minister the gospel in difficult and dangerous circumstances. Literature is provided with other resources and equipment for evangelistic presentations.

4. Providing Bibles, literature and qualified teachers to equip the church to survive and grow despite difficult circumstances, sponsoring Christian radio broadcasts, supporting underground Bible schools to train emerging Christian leaders in areas where the church is being persecuted
5. Being advocates and a voice for the martyrs and the oppressed by raising public awareness of particular situations, campaigning through letter-writing on behalf of those who are imprisoned and tortured for their Christian faith



RELEASE INTERNATIONAL produces excellent publications giving information about what is happening to the Christian Church across the world. They also have an excellent website

(www.releaseinternational.org), where you can sign up to receive regular e-mails giving up-to-date prayer requests.

More information is available from the mission display area. If you would like to give please use the special envelopes and place your donation in the offertory at any Sunday service. Please complete a Gift Aid Slip if appropriate.

Thank you

ALSO – don't forget our Mission Supper on Saturday 6th November at 7.30pm when our speaker will be Andrew Wilson from Release International. He will also be speaking at our Sunday morning services on the 7th which is designated International Day of Prayer for the Persecuted Church. Free supper tickets are available from the Missions Group; Ron & Janet Goodenough, Jean Gardiner, Fiona Flett, John Barling and Val Cookney.

November Church Diary

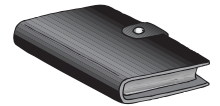

2nd

Tuesday 7:00pm ALPHA

4th

Thursday 8.00pm House Groups

5th

Friday Bonfire Night - church open to serve Hot Chocolate from 6.30pm

6th

Saturday 8.45 — Prayer Meeting
9.30am at Evangelical Free
ALPHA Away Day at Tiger
7.30 pm Mission Supper with Andrew Wilson from Release International

7th
Sunday

9.30am Andrew Wilson - Communion
11.00am Andrew Wilson
3:00pm Compton House Anniversary.
6.30pm Charles Martin

9th

Tuesday 7:00pm ALPHA

10th

Wednesday 12.30pm Lunch Fellowship

11th

Thursday 8.00pm Church AGM

12th

Friday 12.30pm Lunch Fellowship

13th

Saturday 8.45 — Prayer Meeting
9.30am at Evangelical Free

14th
Sunday

9.30am Charles Martin
10.55am Charles Martin - Remembrance
6.30pm Charles Martin - Communion

16th

Tuesday 7:00pm ALPHA

18th

Thursday 8.00pm House Groups

20th

Saturday 8.45 — Prayer Meeting
9.30am at Evangelical Free

21st
Sunday

9.30am David Jones
Fair Trade stall
11.00am David Jones
6.30pm Ron Goodenough

23rd

Tuesday 7:00pm ALPHA

7:45pm In Touch -
"Relaxing before
Christmas" *venue TBC.*

24th

Wednesday 2.30pm The Fellowship.
7.00pm Elders meeting

25th

Thursday 8.00 pm Church Prayer Meeting (Lounge)

27th

Saturday 8.45 — Prayer Meeting
9.30am at Evangelical Free

28th
Sunday

9.30am Charles Martin
11.00am Charles Martin - Communion
6.30pm Jenny Martin

Balcombe United Reformed Church

Bramble Hill, Balcombe RH17 6HR

Our services are held weekly at 10.30am.
Visitors are welcome to join us.



Speakers for November are as follows:-

November 7th	Mike Gardiner
November 14th	Philip Wren
November 21st	Charles Martin
November 28th	Philip Wren

FLOWER ROTA



Arranging

Distributing

November

7th	Heather Swann	Jo Bloxham
14th	Betty Billins	Heather Swann
21st	Sue Waller	Iris Bingham
28th	Wedding Flowers	Janet Sanderson

December

5th	Carol Walters	Sue Tester
12th	Serena Nathan	Jacqueline Wood
19th	Christmas Flowers	Barbara Shepherd
26th	Christmas Flowers	No distribution

Sunday Services explained....

The **9.30am service** is an opportunity for all age groups to join in a relaxed informal time. There is a crèche, and after about 20 minutes, children and young people up to age 14 go out to their own groups on most Sundays.

Coffee is served between the morning services.

The **11:00am service** is usually more set and formal.

(Exceptions to these times are shown in the Diary).

At **6:30pm** it is sometimes a celebration, sometimes a quieter ministry time and sometimes an open communion service or something quite different!

Personal prayer is available after every service. Prayer requests and brief statements of praise for answered prayer can be put in the red book on the concourse table. We can also offer personal prayer ministry at home or in hospital.

We do not take up an offering during the services, but those wishing to give are invited to place a gift in one of the bowls at the doors before or after the service. Thank you.

Recordings of services can be borrowed free from the church.

Across

- 1 'The Lord Jesus... took bread, and when he had given — , he broke it' (1 Corinthians 11:24) (6)
- 4 'He has taken me to the banquet hall, and his — over me is love' (Song of Songs 2:4) (6)
- 8 Surrey town that hosts the National Christian Resources Exhibition (5)
- 9 Also known as Abednego (Daniel 1:7) (7)
- 10 Liken (Isaiah 40:18) (7)
- 11 A son of Etam, descendant of Judah (1 Chronicles 4:3) (5)
- 12 A part of the temple where the blood of a young bull was to be smeared (Ezekiel 45:19) (9)
- 17 'They make many promises, take false — and make agreements' (Hosea 10:4) (5)
- 19 Roman province to which Paul returned after evangelizing it on his first missionary journey (Acts 16:6) (7)
- 21 Material used to make baby Moses' basket (Exodus 2:3) (7)
- 22 'And feeble as — , in thee do we trust, nor find thee to fail' (5)
- 23 'The watchman opens the gate for him, and the sheep — to his voice' (John 10:3) (6)
- 24 Stalk carrying the sponge of wine vinegar given to Christ on the cross (John 19:29) (6)

Down

- 1 Elijah dug one round the altar he built on Mount Carmel and filled it with water (1 Kings 18:32) (6)

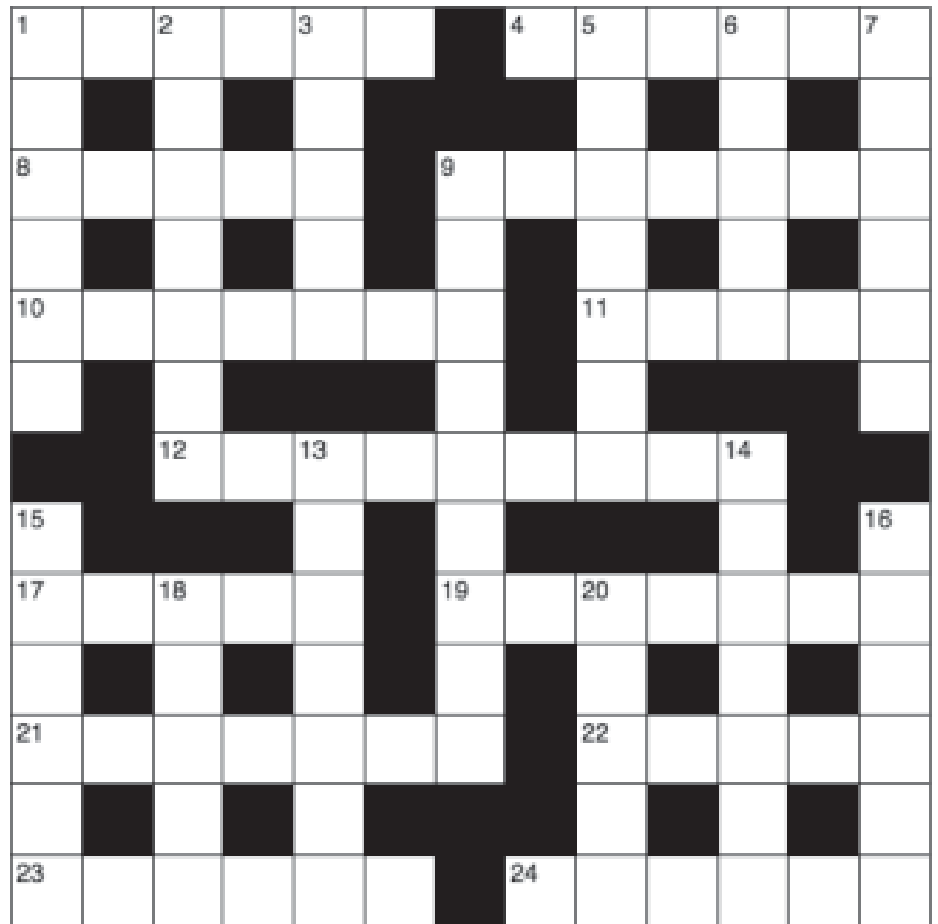

- 2 'I am not — of the gospel, because it is the power of God for the salvation of everyone who believes' (Romans 1:16) (7)
- 3 Buddhist term relating to belief in reincarnation (5)
- 5 Damascus disciple who, at God's command, restored the sight of the blinded Saul of Tarsus (Acts 9:12) (7)
- 6 and 16 Horses: their sound (Jeremiah 50:11) (5) and their gait (Joel 2:4) (6)
- 7 A three (anag.) (6)
- 9 Athenian council addressed memorably by Paul (Acts 17:22) (9)
- 13 Abide by (Galatians 3:5) (7)
- 14 Persian princes (Daniel 3:2) (7)
- 15 Force (Galatians 6:12) (6)
- 16 See 6 Down (6)
- 18 Paste (anag.) (5)
- 20 How the cedars of Lebanon are described (Isaiah 2:13) (5)

My 4th Year at University

As I walk around our new Student's Union building and see the new "freshers", I suddenly feel a lot older. I am now a *fourth* year medical student. When did that happen?

A new year, a new house and new housemates; two other fourth years and one graduate whom I used to row with. We all get on well and enjoy our exercise, so consume a ridiculous amount of food (when there is some in the house). After three years of rowing for the university, I felt it was time for a change. So, I have taken up triathlon (swim, bike, run) to satisfy the training void left by rowing. I have joined the local triathlon club as well as the university's running and swimming clubs, which have been great for meeting new people and learning new skills.

I've been attached on an orthopaedic rotation for the last few weeks. This has been great fun, scrubbing in to help out during many different operations involving ankles, hips and shoulders, for example. Lots of fun tools!

I've continued to go to Trinity Life Church and really value being able to go to a church where I feel comfortable whilst I'm in Leicester. It is really multicultural and there is good energy so it is a great place to go to feel uplifted.

(PTO)

Update on our Students

Jonathan Hall

4th year Medicine – Leicester

Alex Hall

3rd year Medicine – Imperial College

Helen Merrett

Exeter

Helen is currently in Germany on her 3rd Year abroad. She is teaching in a school for 10-16 year olds

Sam Griffiths

3rd year Landscape Architecture and Ecology – Sheffield

Sam is President of the C.U.

Katie Cookney

2nd year Medicine – Cardiff

Katie is Hall group Leader and Revive Team Leader.

Rosie Fruin

1st year Media Production – Lampeter

Megan Comber

1st Year Sports & Exercise Science – Bath



For our students we pray:
".... asking God to fill you with the knowledge of his will through all spiritual wisdom and understanding. And we pray this in order that you may live a life worthy of the Lord and may please him in every way; bearing fruit in every good work, growing in the knowledge of God, being strengthened with all power according to his glorious might so that you may have great endurance and patience, and joyfully giving thanks to the Father who has qualified you to share in the inheritance of the saints in the kingdom of light."

Col 1: 9-12

Looking to the future, I'm trying to gain as much experience as possible to help me in my application to take a year out of my medical degree to complete an intercalated BSc in Sports and Exercise Medicine in London, as this is what I'd love to eventually specialise in. I would really appreciate your prayers in helping me achieve this.

Thank you for all your messages and prayers over the last few years. I look forward to seeing everyone again soon!

Jonathan Hall

Please cut out the Bookmark and Prayer to the left, and use as a reminder to pray for our Students.

Autumn Fair:

Following on from the great success of the Spring Fair to support Compton House, there will be an Autumn Fair on Saturday 13th November in our church premises.

We are particularly keen to raise money from sales from cakes of any kind. If you can help, please sign the sign-up sheets on the notice boards.

Most importantly, please tell your friends and neighbours about the Fair and display a poster.

Thank you, Stuart Marsh (483500)

You are invited to an

Autumn Fair



**Christmas
Gifts**

Cakes

Plants

Crafts

Cards

Refreshments

Jewellery

Saturday 13th November

10:00am until 12 noon

**at Lindfield United Reformed Church
High Street, Lindfield**

This event is to support
Lindfield Christian Care Home
(‘Compton House’)



ADMISSION FREE

We look forward to seeing you!

Operation Christmas Child

Samaritan's Purse

Shoebboxes

We will be 'doing' shoebboxes again this year so if you would like to fill one please take a leaflet from the Mission Display Area giving information

They need to be brought to the church on or before Sunday November 14th

Thank you

Book Review

Morning and Evening: Charles H. Spurgeon (Revised and updated by Alistair Begg)

"Charles Spurgeon's 'Morning and Evening' has earned the right to be called a devotional classic. Generations after Spurgeon's death, Christians are still finding his timeless and original engagement with God's word to be a refreshing way to begin and end their day.

....Noted pastor and author Alistair Begg has updated Spurgeon's language while preserving the dignity and clarity of Surgeon's original words."

(Quoted from the back cover of 'Morning and Evening'.)

We first brought this book back in April, and since then I have found it to be a source of treasures to take with me at the beginning of each day. Each day has two parts, for morning and evening. Beginning with a verse, it is then followed by Spurgeon's comments on the verse, giving insights, encouragement and challenges.

If you think you have no time for a quiet time at the beginning of the day, I would dare to say that this devotional book is worth re-thinking that and making time for. To begin a day with a verse, from the Bible explained so clearly and unequivocally is a start that really can make a difference to the day.

To conclude with a quote again from the back cover, in this book you will find "...strength for today and hope for tomorrow through Spurgeon's faithful teaching of Scripture."

Val Cookney

FAMILY NEWS

Thank you from Brenda Johnson

I would like to express my sincere thanks to everyone who gave me so much support during my recent spell in hospital and afterwards at home. I have been really upheld through prayer, by the many cards, gifts and visits that I have received. As I write this I am still in the early stages of recovery but hopefully by the time you read this in the November magazine I will be back in circulation and well on the road to recovery. I would like to mention two friends in particular, the first being Fo, who co-ordinated information and visits whilst I was in Brighton Hospital for 3 weeks and also Jean Gardiner who took over that role when I returned home. By drawing together a rota of helpers who called in every day to assist me in any task that I was unable to do myself, I was never far from encouragement and love that has shown itself over the weeks in so many different ways. I feel it a privilege to belong to our church family.

Brenda Johnson

Over the weekend of October 9th and 10th we celebrated Hilary Greatwood's 90th Birthday and sadly, we bade farewell to Hilary in the Morning Service because two days later she flew with her family to Australia where she will live permanently. Hilary came to Lindfield in 1937 and has been a very active member of the local community and in later years also very involved in Church activities here. We shall all miss Hilary very much but trust she will find a new church family in Oz and quickly settle into her new area.

For correspondence Hilary can be contacted by email at hilarygreatwood@yahoo.com.au or write to her

c/o Mr & Mrs C Edge

4. Barbical Place

Lesmurdie

W A 6076

AUSTRALIA

We were saddened to hear that Chris Caswell has lost her much loved brother recently, please remember all their family at this sad time.

One of our members, Heather Barling, was knocked off her bicycle and at time of writing, after a time in hospital, is recovering at home with a fractured skull. We hope and pray that by the time this is published Heather is well on the way to a full recovery and back with us. Please contact John (482415) before visiting.

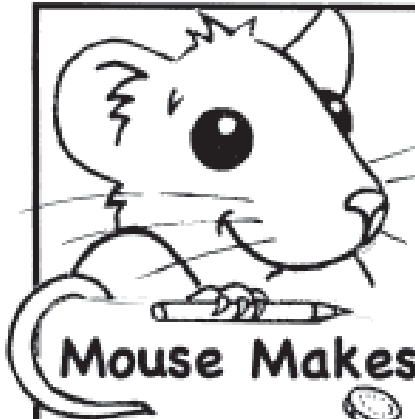

Mouse Makes

Share a little of what God has given you and help other children in the world who are in great need. Make this little money box to save some pennies or other coins in. When full send it on to a charity that helps others.

glue

"Do not forget to do good and to share with others, for with such sacrifice God is pleased".
Hebrews 13:16

cut out



God is able to give you more than you need, so that you will always have all you need for yourselves and more than enough for every good cause'
2 Corinthians 9:8

Jesus said
"As I have loved you, so you must love one another"
John 13:34

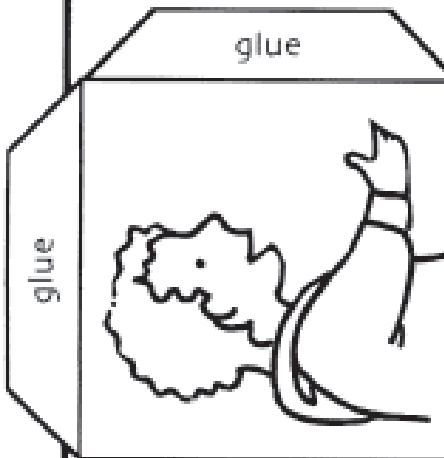

glue

"Lord, help us to remember and to give thanks for all that you have done for us"



Enlarge this page by 140% and print out onto a sheet of card. Cut around the outside then ask an adult to cut out the coin slot. Colour in. Fold along the lines and glue together to make a cube.

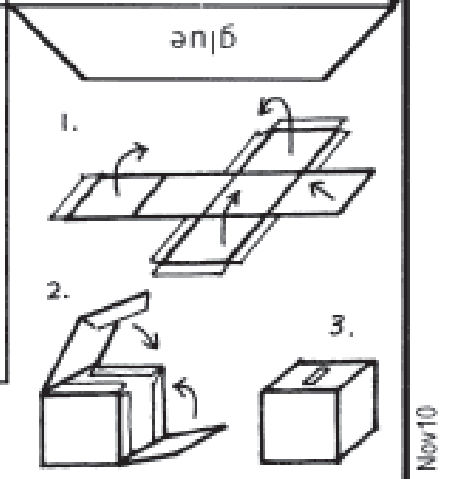
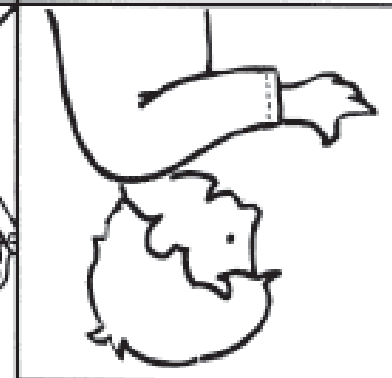

Nov10

Something Different

Tunes and Tea

20th November at 3-00pm

Lindfield URC.

Following the success of Lindfield Arts Day and the Messy Church Saturdays we are holding a concert on a **Saturday afternoon**. The date being 20th November at 3-00pm and finishing at 5-00pm. We have called the event **TUNES and TEA** and there will be an interval and time to have a chat.

We are delighted that the singing group **Sister, Sister** will be taking part plus the Lindfield URC Sunday Morning Singers.

Supporting the music will be the Perdido Players Swing band. Saxophone solos, Flugel Horn and even possibly a raucous trombone player will share in the programme.

The Perdido vocalists will also take part and that well known (to some) raconteur John Merrett.

As you can see there will be a wide variety of music and hopefully there will be something for everybody.

Admission is free and there will be a retiring collection at the end of the event and any monies after expenses will be sent to Tear Fund to support their relief work in Pakistan.

Have a rest from Christmas shopping and come and enjoy an afternoon of music making and fun.

For more information contact Peter Swann 01444 450335.

Flower Rota - can you help?

I am sure you all like to see flowers in our church on Sundays! Perhaps you could join the Flower Rota team? It would be good if you were able to do them yourself, but there are a few people who could do them for you. Some of our folk arrange them or get help in memory of a loved one. On a Monday they are delivered to the sick or to somebody who needs cheering up. Pray about it and if God answers the calling please see me or phone 484494 and I can fill you in with more details.

Betty Billins

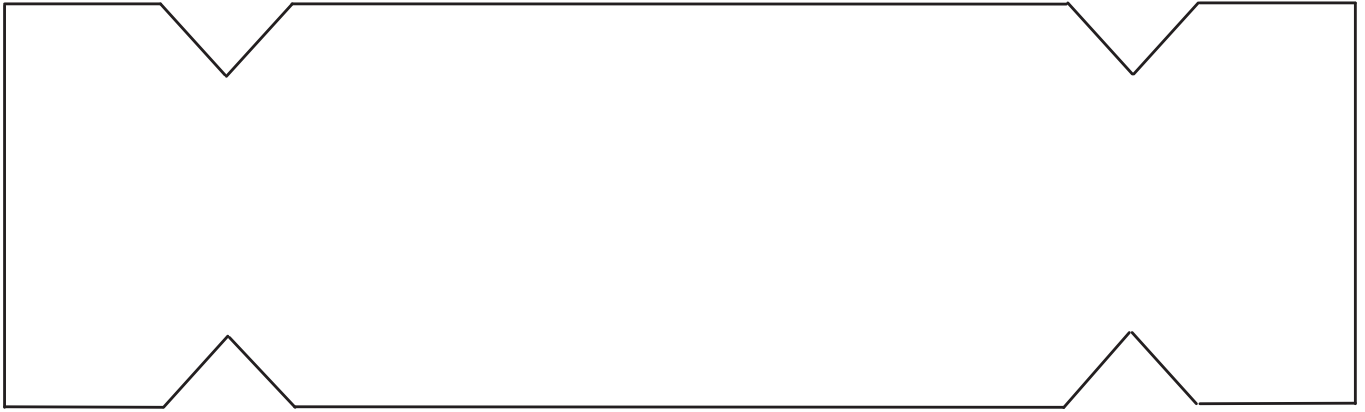

It is that time of year again. For the last few years many of you have used the Christmas cracker to send your Christmas greetings. We have provided a template of a cracker for you to cut out and to put your Christmas message in for printing in the Winter edition. Place in the GoodNEWS pigeon hole - or post to the Church - for the attention of the Editor.

Change of Address:

Harry and Rosemary McCleery have moved to:

Hosanna,
 19 Munnion Road,
 Ardingly,
 West Sussex
 RH17 6RR (Phone number is unchanged).



STOP PRESS!!!

The next Edition of the Good News Magazine will be the **Winter Edition** and will cover December and January. So there will be **NO** magazine in January.

Editorial Team

CROSSWORD ANSWERS

Loffy.

DOWN: 1, Trench. 2, Ashamed. 3, Karma. 5, Ananias. 6, Neigh. 7, Reheat. 9, Areopagus. 13, Observe. 14, Satraps. 15, Compel. 16, Gallop. 18, Tapes. 20,

Hyssop

ACROSS: 1, Thanks. 4, Banner. 8, Esher. 9, Azariah. 10, Compare. 11, Ishma. 12, Doorposts. 17, Oaths. 19, Galatia. 21, Papyrus. 22, Frail. 23, Listen. 24,

SUNDAY WORSHIP:

- 9.30am Service for all the family, including crèche and Lighthouse (Junior church). (Most weeks, children leave after 20 minutes for their own activities)
 Holy Communion (1st Sunday)
- 11.00am Morning Worship
 Holy Communion (4th Sunday)
- 6.30pm Evening Service
 Holy Communion (2nd Sunday)

Healing services as announced

PRAYER MEETINGS:

- Mon 9.30am An Hour of Prayer
- Wed 9.45am Short Service of Intercession
- Thur 8.00pm Church Prayer Evening
 (As announced)
- Sat 8.45am Three Churches Prayer Meeting.
 – 9.30am Venue rotates between the three churches.

REGULAR ACTIVITIES:

- Mon 10.00am Art Group
- 5.45pm Boys' Brigade - Anchor Boys
 (5–7 years)
- 6.15pm Boys' Brigade - Junior Section
 (8–11 years)
- 7.15pm Boys' Brigade – Company
 Section (11+ years)
- Tue 10.00am Stepping Stones
 (Parents and toddlers - term time)
- 7.45pm In Touch (4th Tues) for women
 of all ages
- Wed 2.30pm The Fellowship (4th Wed)
 for mature ladies and gentlemen
- Thur 10.00am Pop-In (for coffee and a chat)
- 8.00pm Church Meeting (2nd Thur)
- Fri 7.15pm Zest (Years 6–9) games,
 craft, tuck and a bible message
 (term time)

Sun 8.00pm Youth Fellowship

House Groups normally meet 1st and 3rd
 Thursday

The church is normally open Monday to Saturday
 from 10.00am to 12.30pm

Church Office: 01444 482098

Church (payphone): 01444 484620

Charles Martin (Minister)

Mobile No: 07821 904785

Josh Thomas (Youth Pastor)

Mobile No: 07598 779553

Boys' Brigade:

Geoffrey Cocksedge 01444 474007

Cradle Roll:

Sue Tester 01444 482810

Flowers:

Betty Billins 01444 484494

Hall Booking Secretary:

Carol Walters 01444 457938

In Touch:

Sue Waller 01444 455047

Lunch Fellowship:

Wednesday:

Janet Drayton 01444 483621

Friday:

Gwen Hillman 01444 456963

Anne Parker 01444 473519

Magazine: Editor:

Val Cookney 01444 440029

The Fellowship:

Chris Comber 01444 482641

Stepping Stones:

Janet Goodenough 01444 417002

Transport:

Ray Smith 01444 484427

Zest Co-ordinator:

Clare Nibloe 01444 484683

Lighthouse (Junior church)

Co-ordinator:

Dawn Walters 01444 441601



ARDINGLY CHORAL SOCIETY
REMEMBRANCE CONCERT
DOLPHIN CENTRE

SUNDAY, 14TH NOVEMBER 7.30PM

MID SUSSEX SINFONIA

MESSE SOLENELLE DE SAINTE CECILE GOUNOD
1812 OVERTURE TCHAIKOVSKY WITH CHORUS
WITH CHILDRENS CHOIR

TICKETS £12 from Mrs Shirley Ventham 01273 831264
or at Door

Concess: £10

Children: Free

In Aid of the ROYAL BRITISH LEGION



HAYWARDS HEATH MUSIC SOCIETY

Saturday 27 November

Pavlos Carvalho (cello) and the Manus Ensemble

7.45 pm at St Wilfrid's